



## 24V 300W 1 Phase



### Features:

- Full aluminium casing for lightweight and corrosion resistant handling
- Ease of wire connection to Terminals
- Remote On/Off function
- Remote Sense Function
- Built-In 12V STANDBY
- Active PFC Function, PF> 0.96
- Universal AC input
- Overload protection
- Over voltage protection
- Thermal protection
- Efficiency> 87%typ.
- Expected life time: 10 years
- 2 year warranty
- RoHS compliant

## PMC-24V300W1AE

### Summary

The new Hi-End series with Remote Sense Function & 12V STANDBY / 0.5A Enclosed Power Supply is the latest offering from one of the world's largest power supply manufacturers and solution providers - FORTE.

The product range offers a nominal output voltage of 24V, a wide temperature range from -10°C to +70°C and a highly dependable minimum holdup time.

The state-of-the-art design is made to withstand harsh industrial environments. What makes the product stand out from the crowd is its lightweight full aluminum body design which can withstand shock and vibration according to IEC60068-2.



FORTE's Panel Mount Power Supply also offers overvoltage and overload protection. Using a wide input voltage range design, it is compatible worldwide. The input also includes DC operating voltage from 120-375Vdc. Best of all, this excellent design and quality does not come with a big price tag.



## Technical Data

### PMC-24V300W1AE

#### 1.) Input Data

|                             |                                  |
|-----------------------------|----------------------------------|
| Input Voltage (Nominal)     | 100 - 240Vac                     |
| Input Voltage range         | 85 - 264Vac                      |
| Input Frequency (Nominal)   | 50 - 60Hz                        |
| Input Frequency range       | 47 - 63Hz                        |
| DC Input Voltage (Nominal)  | 125 - 250Vdc                     |
| DC Input Voltage Range      | 120 - 375Vdc                     |
| Input Current               | < 4.0A @ 115Vac, < 2.0A @ 230Vac |
| Efficiency                  | > 86% @ 115Vac & > 88% @ 230Vac  |
| Inrush current (Cold Start) | < 35A @ 115Vac, < 70A @ 230Vac   |
| Leakage Current             | < 1mA @ 240Vac                   |

#### 2.) Output Data(24VDC)

|   |  |
|---|--|
| Output Voltage (Nominal)                              | 24 Vdc   |
| Output Voltage Tolerance                              | +/- 2% (Initial set point tolerance)                     |
| Output Voltage Adjust Range                           | 22 - 28 Vdc  |
| Line Regulation                                       | < 0.5% Typical @ 85 to 264Vac input, 100% load           |
| Load Regulation                                       | < 1% Typical @ 85 to 264Vac input, 0 to 100% load        |
| Ripple & Noise (PARD), 20MHz BW                       | < 100mVpp (25°C)   |
| Output Current (Nominal)                              | 12.5 A   |
| Power Derating above 50°C                             | Derated Linearly 2.5% / °C                               |
| Rise Time   | < 30 ms @ nominal input, 100% load (25°C)                |
| Start-Up Time   | < 1000 ms @ nominal input, 100% load (25°C)              |
| Hold-Up Time  | > 15ms @ 115Vac & 230Vac (100% load, 25°C)               |
| Dynamic Response (Overshoot & Undershoot O/P Voltage) | +/-5% @ 0% - 100% load                                   |
| Startup with capacitive loads                         | 8,000µF @ nominal input & nominal O/P voltage 24V (25°C) |

#### 3.) Protection (24VDC)

|                                    |   |
|------------------------------------|---|
| Over Voltage Protection            | 32V +10%/-10%, SELV output, Hicc-up Mode, Non-Latching (Auto recovery).   |
| Over load, Over current Protection | > 120% of rated load current, Hicc-up Mode, Non-Latching (Auto recovery). |
| Over Temperature Protection        | < 75°C Ambient Temp@ 100% load. Non-Latching (Auto-recovery).             |
| Short Circuit Protection           | Hicc-up Mode, Non-Latching, (Auto-recovery when the fault is removed).    |

#### 4.) Output Data(12Vsb)

|   |   |
|---|---|
| Output Voltage (Nominal)                              | 12 Vdc  |
| Output Voltage Tolerance                              | +/- 2% (Initial set point tolerance)              |
| Output Voltage Adjust Range                           | 11.4 – 12.6 VDC                                   |
| Line Regulation                                       | < 0.5% Typical @ 85 to 264Vac input, 100% load    |
| Load Regulation                                       | < 1% Typical @ 85 to 264Vac input, 0 to 100% load |
| Ripple & Noise (PARD), 20MHz BW                       | < 100mVpp (25°C)                                  |
| Output Current (Nominal)                              | 0.5 A   |
| Power Derating above 50°C                             | Derated Linearly 2.5% / °C                        |
| Rise Time   | < 30 ms @ nominal input, 100% load (25°C)         |
| Start-Up Time   | < 1000 ms @ nominal input, 100% load (25°C)       |
| Hold-Up Time  | > 15ms @ 115Vac & 230Vac (100% load, 25°C)        |
| Dynamic Response (Overshoot & Undershoot O/P Voltage) | +/-5% @ 0% - 100% load                            |

#### 5.) Protection (12Vsb)

|                                    |   |
|------------------------------------|---|
| Over Voltage Protection            | > 16V +/-15%, SELV output, Non-Latching (Auto recovery).                  |
| Over load, Over current Protection | > 120% of rated load current, Hicc-up Mode, Non-Latching (Auto recovery). |
| Over Temperature Protection        | < 75°C Ambient Temp@ 100% load. Non-Latching (Auto-recovery).             |
| Short Circuit Protection           | Hicc-up Mode, Non-Latching, (Auto-recovery when the fault is removed).    |



| 6.) Environmental               |   |
|---------------------------------|---|
| Ambient temperature (Operating) | -10°C to +50°C, with operation to 70°C possible with a linear derating to half power from 50°C to 70°C.     |
| Ambient temperature (Storage)   | -25°C to 85°C   |
| Altitude (Operating)            | 3,000 Meters  |
| Shock Test                      | IEC60068-2-27, 30G (300m/s <sup>2</sup> )   |
| Vibration (Non-Operating)       | IEC60068-2-6, 10Hz to 150Hz @ 50m/s <sup>2</sup> (5G peak) for all X, Y, Z direction                        |
| Bump                            | IEC60068-2-29, 11ms/ 10gn   |
| MTBF                            | > 700,000 hrs, as per BELL CORE STD or IEC61709<br>Tested at 115Vac & 230Vac input, 100% load, 25°C ambient |
| Expected Cap Life Time          | 10 years (115Vac & 230Vac, 50% load and 40°C ambient).  |
| Material and Parts              | RoHS directive, WEEE directive  |
| Degree of protection            | IP20  |
| Class of protection             | Class I with PE connection  |
| Pollution degree                | 2   |

| 5.) Mechanical Data     |  |
|-------------------------|--|
| Dimension               | 199 mm X 105 mm X 41 mm (L X W X H)                                      |
| Weight                  | 0.82kg   |
| Cooling System          | Fan  |
| Input & Output Terminal | Terminal Block with screw M3.5 x7 pins Flip-Top type (rated 300VAC, 20A) |
| Indicator               | Green LED (DC OK)  |
| Casing                  | Aluminium  |

| 6.) Safety Standards/EMC  |   |
|---|---|
| <b>Safety Standards</b>   | UL/cUL recognize to UL60950-1 and CSA C22.2 No.60950-1, CB test certificate and report to IEC60950-1, SIQ to EN60950-1, CE (EMC and Low Voltage Directive), CCC |
| <b>EMI</b>  | FCC Title 47, Class B / EN55022, CISPR22, CLASS B<br>EN61000-3-2 (Limitation of mains harmonic currents)  |
| <b>EMS</b>  |   |
| • EN 61000-4-2 <sup>1)</sup><br>Electrostatic Discharge Standard (ESD)  | Air Discharge: 15 KV<br>Contact discharge: 8 KV   |
| • EN 61000-4-3 <sup>1)</sup><br>Radiate Field Immunity  | LEVEL 3<br>80MHz - 1GHz / 10V/M with 1kHz tone / 80% modulation.  |
| • EN 61000-4-4 <sup>1)</sup><br>Fast transients (Burst Immunity)  | LEVEL 3<br>2 KV <sup>4)</sup>   |
| • IEC 61000-4-5 <sup>1)</sup><br>Surge voltage Immunity   | LEVEL 3<br>Common Mode: 2 KV <sup>3)</sup><br>Differential Mode: 2 KV <sup>4)</sup>   |
| • EN 61000-4-6 <sup>1)</sup><br>Conducted Immunity  | LEVEL 3<br>150KHz - 80MHz / 10Vrms.   |
| • EN 61000-4-8 <sup>1)</sup><br>Power frequency magnetic field  | LEVEL 3<br>10A/Meter  |
| • EN 61000-4-11 <sup>2)</sup><br>Voltage dips   | Input 100% dip 1 cycle, Main Buffering > 20ms, Self Recoverable   |
| • IEC 61000-4-12 <sup>1)</sup><br>Low Energy Pulse Test (Ring Wave)   | LEVEL 3<br>Common Mode: 2 KV <sup>3)</sup><br>Differential Mode: 1 KV <sup>4)</sup>   |
| <b>Galvanic Isolation :</b>   |   |
| Input / output  | type test/routine test : 3KVac  |
| Input / PE  | type test/routine test : 1.5KVac  |
| output / PE   | type test/routine test : 0.5KVac  |
| 1) Criterion A: Normal operating behavior within the defined limits.<br>2) Criterion B: Temporary impairment to operational behavior that is corrected by the device itself.<br>3) Symmetrical: Conductor to conductor.<br>4) Asymmetrical: Conductor to ground.<br>5) Class B: Area of application industry and residential. |   |



## Engineering Data

- Derating Curve
- PMC-24V300W1AE

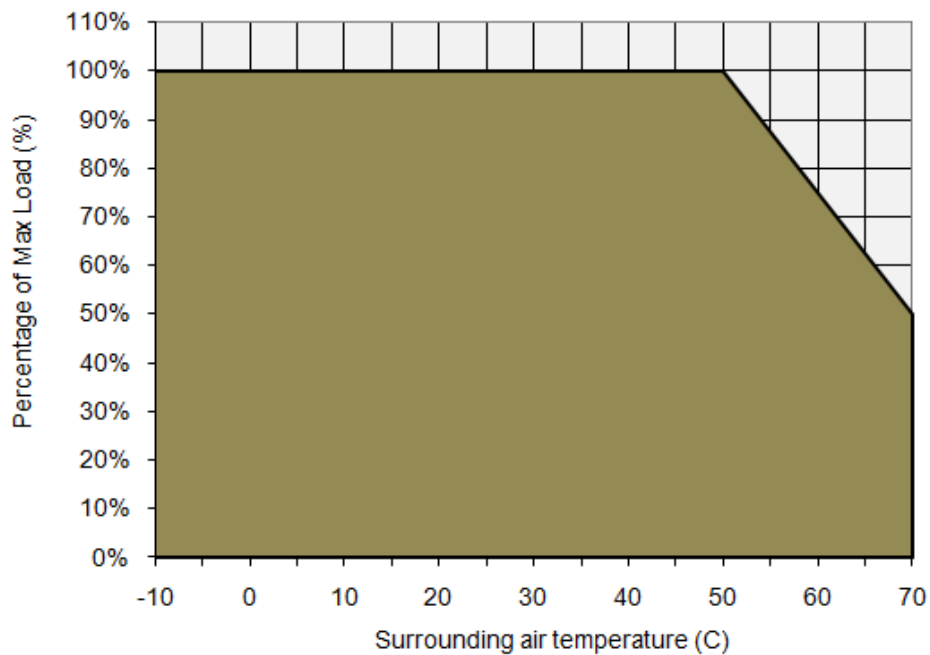

### Note:

1. Do not use the Power Supply in areas outside the shaded portion as shown in the above graph, internal parts may occasionally deteriorate or be damaged.
2. For the power derating refer above graph ambient temperature  $> 50^{\circ}\text{C}$ , the output capacity has to be reduced by 2.5% per Kelvin increase in temperature. If the output capacity is not reduced when  $\text{Amb} > 50^{\circ}\text{C}$  device will run into thermal protection by switching off i.e. device will go in bouncing mode and will recover when  $\text{Amb}$  is lowered or load is reduced as far as necessary to keep device in working condition.
3. If the power supply has to be mounted in any other direction please contact your service provider.
4. In order for the device to function in the manner intended, it is also necessary to observe lateral spacing of 2 cm to other modules.
5. Depending on the ambient temperature and load of the device, the temperature of the housing can become very high!



## Mechanical drawing

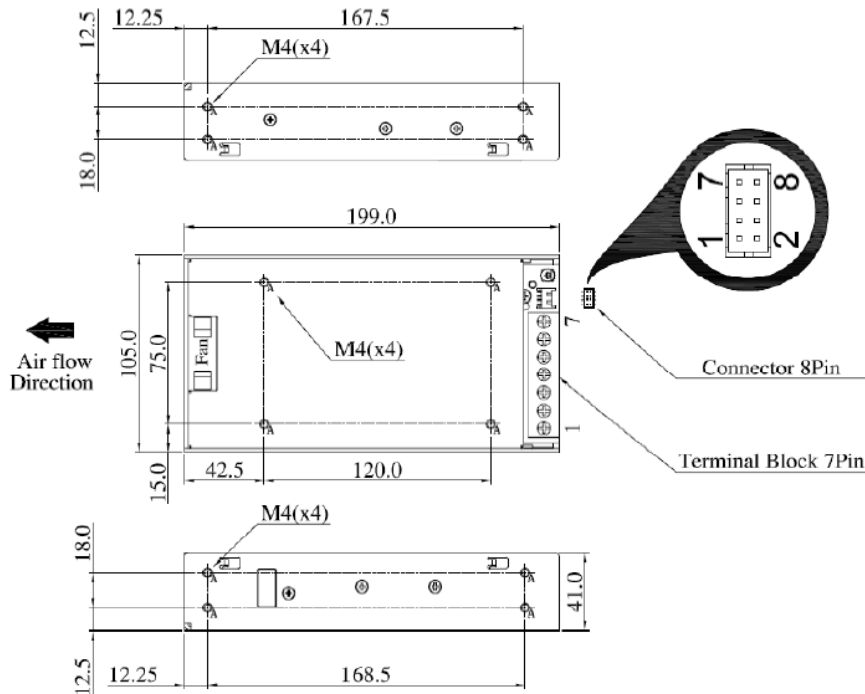

### Terminal Pin Assignment.

| Pin No. | Assignment   |
|---------|--------------|
| 3       | GND          |
| 4,5     | DC OUTPUT -V |
| 6,7     | DC OUTPUT +V |

### Connector Pin Assignment.

| Pin No. | Assignment    |
|---------|---------------|
| 1       | Remote on/off |
| 2,4,6   | NC            |
| 5       | GND           |
| 7       | +S            |
| 8       | -S            |

## Function Description of CN100

| Pin No. | Function      | Description   |
|---------|---------------|---|
| 1       | Remote on/off | Turns the output on and off by electrical SW or dry contact between Pin 3 (Gnd), Short: Power OFF, Open: Power ON |
| 2,4,6   | NC            | No Application  |
| 3       | 12V/0.5A      | Auxiliary voltage output 11.4 12.6V, Reference to Pin 3 (Gnd). The maximum load current is 0.5A                   |
| 5       | GND           | Ground reference for remote ON/OFF and 12V  |
| 7       | +S            | Positive sensing. The +S signal should be connected to the positive terminal of the load                          |
| 8       | -S            | Negative sensing. The -S signal should be connected to the negative terminal of the load                          |



# Function Manual

## 1. Remote Sense

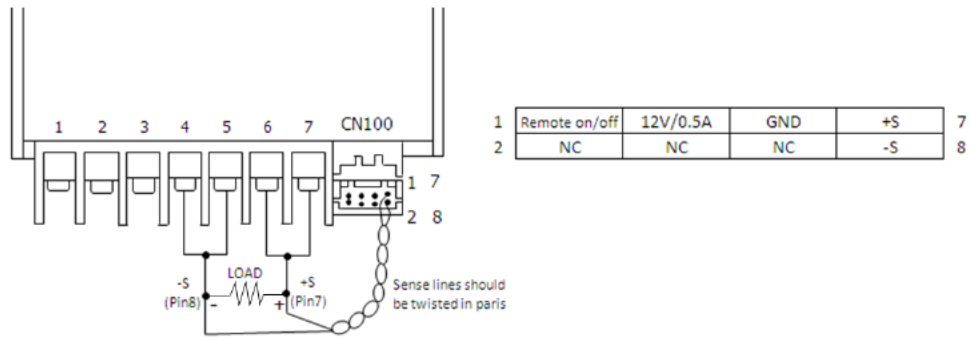

Fig. 1

## 2. 12V/0.5A (Auxiliary Voltage)

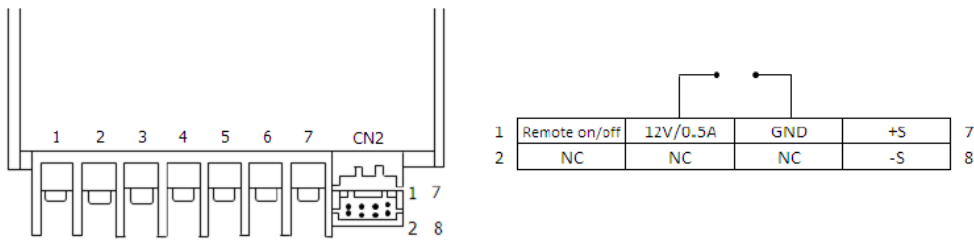

Fig. 2

## 3. Remote Control

The PSU can be turned ON/OFF by using the "Remote ON/OFF" function

| Between RC+(pin3) and RC-(pin5) | Output Status |
|---------------------------------|---------------|
| SW ON (Short)                   | OFF           |
| SW OFF (Open)                   | ON            |

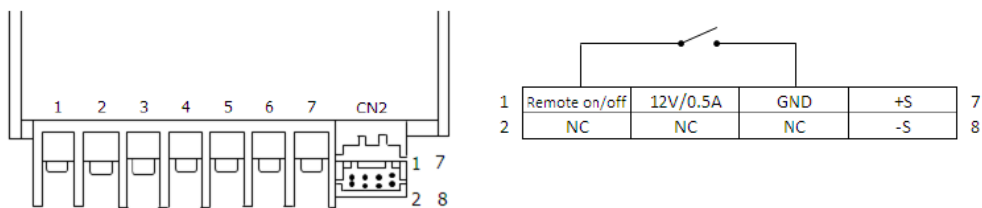

Fig. 3



- **Over Load Protection**

The Power Supply is provided with an overload protection (OLP/OCP) function which protects the power supply from possible damage by over current. Additionally power supply also has over temperature protection (OTP) in case the over load condition persists for a longer duration and is below the overload trigger point but > 100% load.

Typically the over load current ( $I_{OL}$ ) is >  $I_{SURGE}$  (120%) output voltage will start drooping down when the power supply reaches max power limit and will run into bouncing mode when the output reaches UVLO (under voltage point). The output voltage will recover automatically when the overload condition is removed.

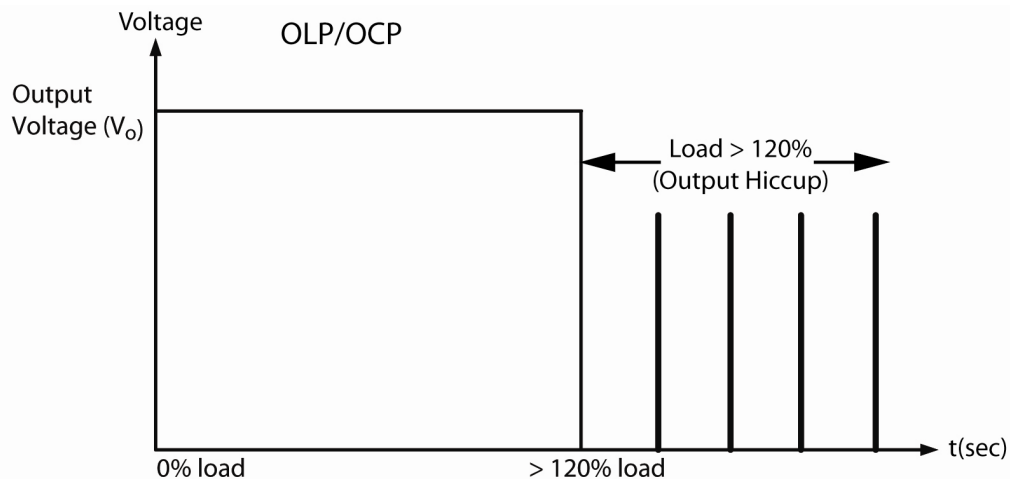

- **Short Circuit Protection**

The Power Supply also has a short circuit protection which is in line with the overload protection and activates whenever there is a short across the output voltage, output goes in bouncing mode and remains until the fault is removed.

- **Over Temperature Protection**

Additionally power supply also has over temperature protection (OTP) as mentioned above this OTP comes into picture when the over load condition persists for a longer duration and the output current level is below the overload trigger point but > 100% load.

Also in the event of a higher ambient operating condition with 100% load the power supply will run into OTP when the Ambient temperature is > 55°C. The protection is self recoverable when activated output voltage bounces until the operating ambient temperature of the power supply is reduced or the power supply is used within its power derating curve.



- **Over Voltage protection (24V)**

The Power Supply is protected by Over voltage in the event that power supply feedback circuit fails the output voltage will not be  $> 32V, +10\%$  under any Line/Load and operating ambient conditions.

The unique feature about this over voltage protection (OVP) is that power supply doesn't shut down but goes Hicc-up mode (Auto recovery) which is  $32V, +/-10\%$ . The power supply output voltage will recover back to  $24Vdc$  once the fault condition is removed.

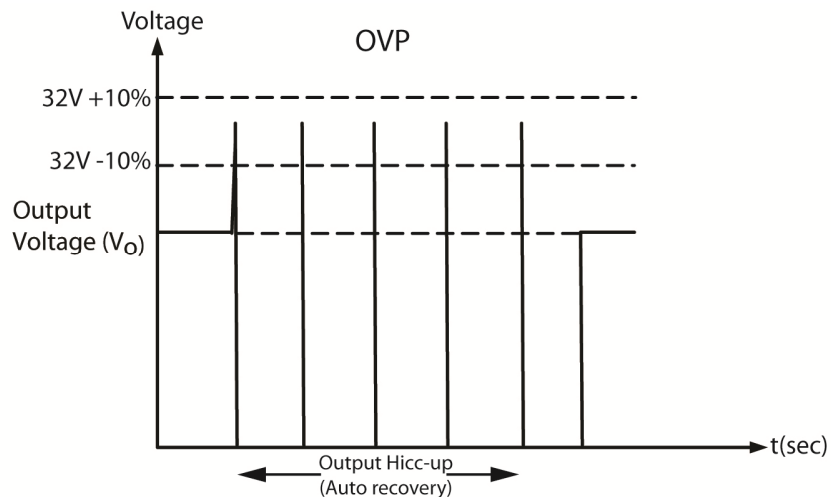

- **Over Voltage protection (12Vsb)**

The Power Supply is protected by Over voltage in the event that power supply feedback circuit fails the output voltage will not be  $> 16V +10\%$  under any Line/Load and operating ambient conditions.

The unique feature about this over voltage protection (OVP) is that power supply doesn't shut down but goes Hicc-up mode (Auto recovery) which is  $16V +10\%, -5\%$ . The power supply output voltage will recover back to  $12Vdc$  once the fault condition is removed.

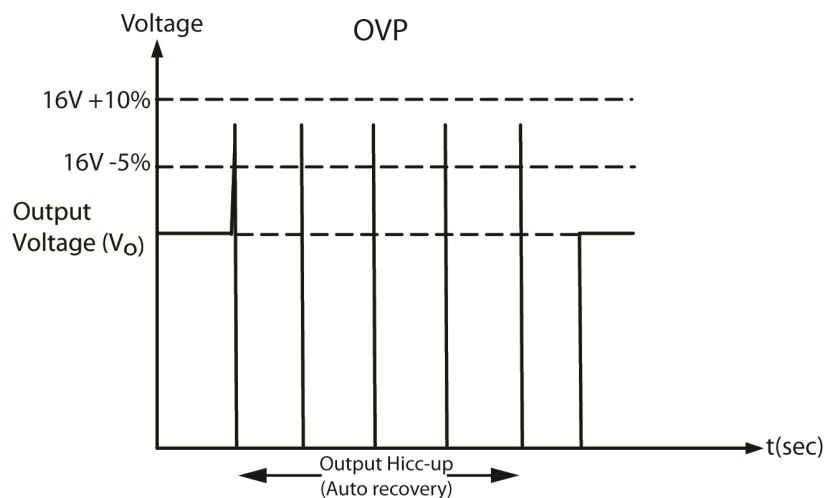





- **Inrush Current, Start Up Time, Output Hold Up Time**

**Inrush Current,**

Inrush current is the first surge current seen on the input side when AC input is applied to the power supply. It is the first pulse captured; see a typical picture for the Inrush current as seen in the power supply.

**Start Up Time,**

Start up time is measured from the point AC input is applied and the o/p voltage reaches within 90% of its set value. See picture below for a typical start up time characteristic of a power supply.

**Rise Time,**

Rise time is the time needed for o/p voltage to rise from 10% of its set value to 90% of its set value. See the picture below for a typical rise time measurement in a power supply.

**Hold Up Time,**

Hold time is the time when the AC input collapses and o/p voltage retains regulation for a certain period of time is called as hold up time. See in the picture below a typical hold up time characteristic of a power supply. The hold time is measured until the o/p voltage remains in regulation hence it is measured until the o/p voltage reaches 95% of its set value.

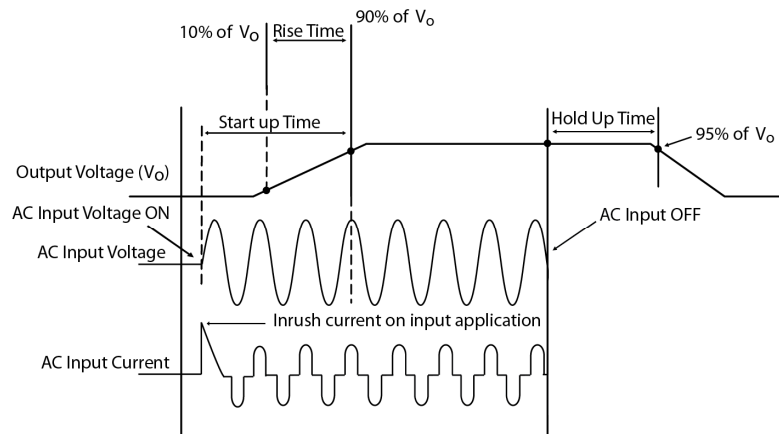

- **Output Voltage Adjust**

The 24VDC connection is made using the "+" and "-" screw connections. At the time of delivery, the output voltage is 24VDC. The output voltage can be set from 22 to 28VDC on the potentiometer seen as Adjust on the front panel of each power supply.



- **Dynamic Load**

Additionally power supply is capable of dynamic change of load from 0% to 100% with o/p voltage within  $\pm 5\%$  of regulation limits. See below the dynamic behavior of the PSU.

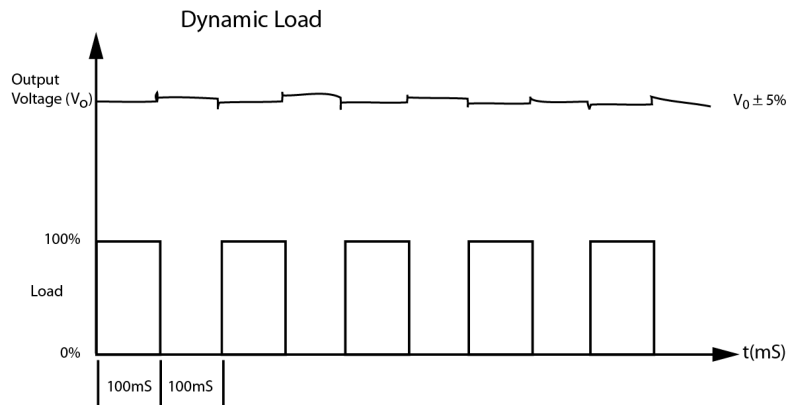

- **Redundancy & Parallel Operation with Oring Diode**

See below figure for a typical Redundant/Parallel operation of PSU using CliQ series power supplies. The 2 power supplies PSU1 & PSU2 are connected thru a twin diode where Anode1 A1 is connected to the +Ve i.e. 24V of PSU1 and Anode2 A2 is connected to the +Ve i.e. 24V of PSU2 and the output ground GND are shorted together.

The output of these 2 power supplies PSU1 & PSU2 is drawn from the Cathode K of the twin diode thus making the power supply work in Redundant/Parallel operation.

**Redundant Operation:**

When 2 power supplies are connected in below manner the power supply PSU1 or PSU2 whichever has higher output voltage takes the max load and the other PSU is operating in standby (@No Load) in case of failure on PSU1, PSU2 takes over the load from PSU1 and supplies the required power to end system.



- **Redundant / Parallel Operation with External Oring Diode**

Redundance / Parallel Operation with External Oring Diode

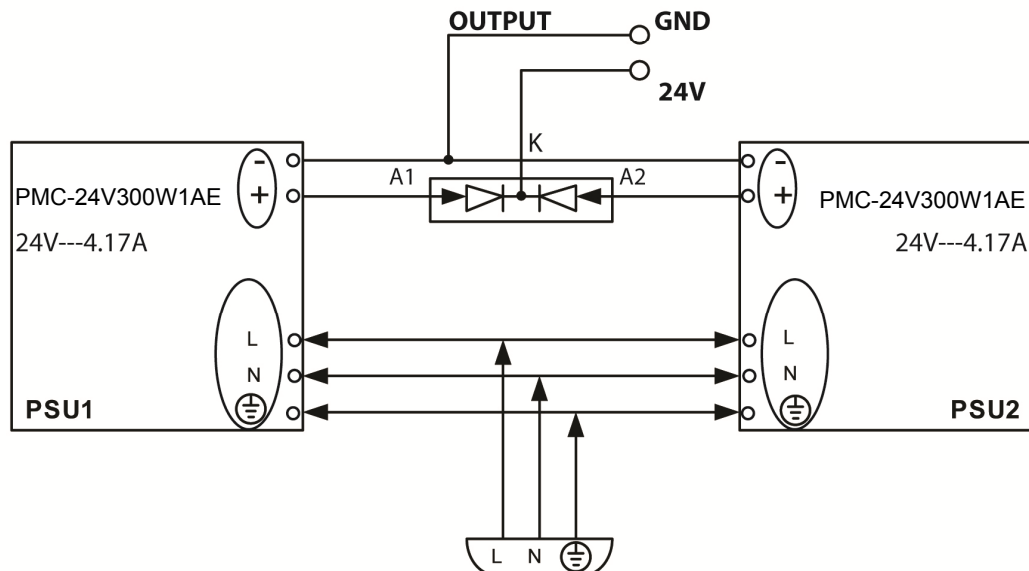
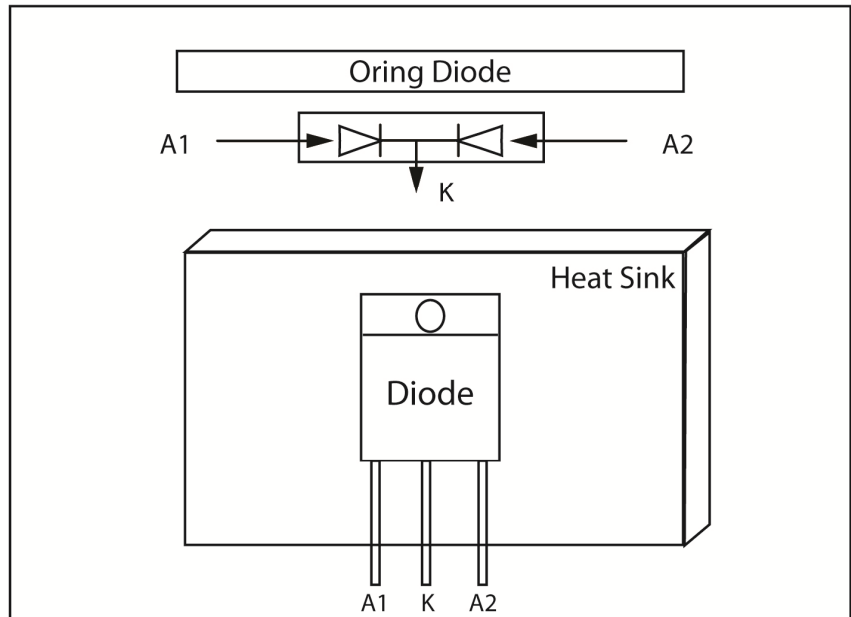

**Parallel Operation:**

When 2 power supplies are also connected in the above manner they can share the Load provided following steps are taken.

**Step 1:**

Measure the o/p voltages @ NL measured from A1 to Gnd i.e. VA1 to Gnd of PSU1 and VA2 to Gnd of PSU2. If the voltages are not same follow step 2, if the o/p voltages are same skip step 2 and move to step 3.

**Step 2:**

Adjust the o/p voltages with the help of VR available on the front panel of the PSU marked as ADJUST for both PSU1 and PSU2 at the same level for e.g. if PSU1 o/p is measuring 24.15Vdc and PSU2 is measuring 24.25Vdc adjust the o/p voltage of either PSU1 close to 24.25Vdc or adjust the o/p voltage of PSU2 close to 24.15Vdc.

**Step 3:**

Connect the PSU to the end system load and measure the o/p voltages from A1 to Gnd i.e. VA1 to Gnd of PSU1 and VA2 to Gnd of PSU2. Ensure that o/p voltages are same even after the 2 power supplies are connected to load. If not then adjust them with the VR available on Front panel. A tolerance of  $\pm 25\text{mV}$  would be acceptable.

**Note:**

1. If the o/p voltage of any 1 power supply i.e. PSU1 or PSU2 is higher that power supply will take the initial load and also share the maximum load.
2. If the o/p voltages adjusted are same then an equal load current sharing between the 2 power supplies can be achieved.
3. The Oring diode must be of an appropriate rating, recommended rating of Oring Diode is minimum 4 times of the output load current and minimum reverse voltage rating of 45Vrr.
4. A suitable HS is also advised to ensure that oring Diode is not over heated and damaged.