

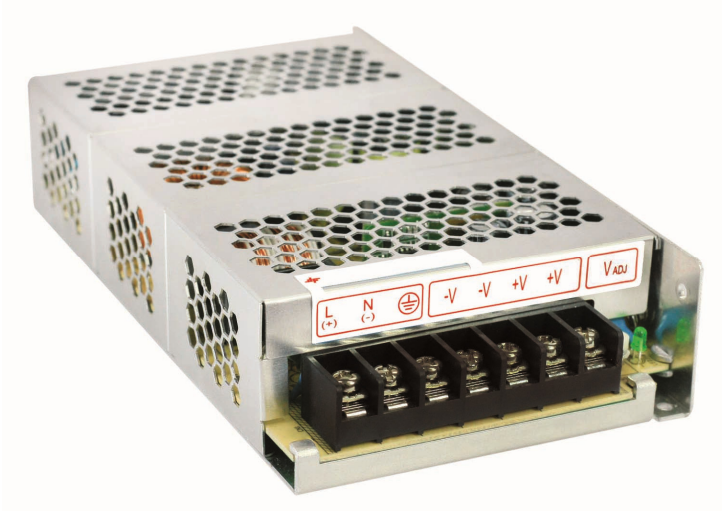

24V 150W 1 Phase



Features:

- Full aluminium casing for lightweight and corrosion resistant handling
- Ease of wire connection to Terminals
- Universal AC input
- Overload protection
- Over voltage protection
- Thermal protection
- MTBF:>700,000hrs
- Efficiency> 86%typ.
- Expected life time: 10 years
- 2 year warranty
- RoHS compliant

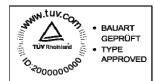

PMC-24V150W1AE

Summary

The new Panel Mount Power Supply is the latest offering from one of the world's largest power supply manufacturers and solution providers - FORTE.

The product range offers a nominal output voltage of 24V, a wide temperature range from -10°C to +70°C and a highly dependable minimum holdup time.

The state-of-the-art design is made to withstand harsh industrial environments. What makes the product stand out from the crowd is its lightweight full aluminum body design which can withstand shock and vibration according to IEC60068-2.

FORTE's Panel Mount Power Supply also offers overvoltage and overload protection. Using a wide input voltage range design, it is compatible worldwide. The input also includes DC operating voltage from 120-375Vdc. Best of all, this excellent design and quality does not come with a big price tag.



Technical Data

PMC-24V150W1AA	
1.) Input Data	
Input Voltage (Nominal)	100 - 240Vac
Input Voltage range	85 - 264Vac
Input Frequency (Nominal)	50 - 60Hz
Input Frequency range	47 - 63Hz
DC Input Voltage (Nominal)	125 - 250Vdc
DC Input Voltage Range	120 - 375Vdc
Input Current	< 3.1A @ 115Vac, < 2.0A @ 230Vac
Efficiency	> 86% @ 115Vac & 230Vac
Inrush current (Cold Start)	< 60A @ 115Vac, < 120A @ 230Vac
Leakage Current	< 1mA @ 240Vac
2.) Output Data	
Output Voltage (Nominal)	24 Vdc
Output Voltage Tolerance	+/- 2% (Initial set point tolerance)
Output Voltage Adjust Range	22 - 28 Vdc
Line Regulation	< 0.5% Typical @ 85 to 264Vac input, 100% load
Load Regulation	< 1% Typical @ 85 to 264Vac input, 0 to 100% load
Ripple & Noise (PARD), 20MHz BW	< 100mVpp (25°C)
Output Current (Nominal)	6.25 A
Power Derating above 50°C	Derated Linearly 2.5% / °C
Rise Time	< 30 ms @ nominal input, 100% load (25°C)
Start-Up Time	< 1000 ms @ nominal input, 100% load (25°C)
Hold-Up Time	> 15ms @ 115Vac, > 80ms @ 230Vac (100% load, 25°C)
Dynamic Response (Overshoot & Undershoot O/P Voltage)	+/-5% @ 0% - 100% load
Startup with capacitive loads	8,000µF @ nominal input & nominal O/P voltage 24V (25°C)
3.) Protection	
Over Voltage Protection	32V +10%/-10%, SELV output, Hicc-up Mode, Non-Latching (Auto recovery).
Over load, Over current Protection	> 120% of rated load current, Hicc-up Mode, Non-Latching (Auto recovery).
Over Temperature Protection	< 75°C Ambient Temp@ 100% load. Non-Latching (Auto-recovery).
Short Circuit Protection	Hicc-up Mode, Non-Latching, (Auto-recovery when the fault is removed).
4.) Environmental	
Ambient temperature (Operating)	-10°C to +50°C, with operation to 70°C possible with a linear derating to half power from 50°C to 70°C.
Operating humidity	< 95%RH
Ambient temperature (Storage)	-25°C to 85°C
Altitude (Operating)	3,000 Meters
Shock Test	IEC60068-2-27, 30G (300m/s ²)
Vibration (Non-Operating)	IEC60068-2-6, 10Hz to 150Hz @ 50m/s ² (5G peak) for all X, Y, Z direction
Bump	IEC60068-2-29, 11ms/ 10gn
MTBF	> 700,000 hrs, as per BELL CORE STD or IEC61709 Tested at 115Vac & 230Vac input, 100% load, 25°C ambient
Expected Cap Life Time	10 years (115Vac & 230Vac, 50% load and 40°C ambient).
Material and Parts	RoHS directive, WEEE directive
Degree of protection	IPX0
Class of protection	Class I with PE connection
Pollution degree	2
5.) Mechanical Data	
Dimension	178 mm X 97 mm X 38 mm (L X W X H)
Weight	0.48kg
Cooling System	Convection
Input & Output Terminal	Terminal Block with screw M3.5 x7 pins (rated 300VAC, 20A)
Indicator	Green LED (DC OK)
Casing	Aluminium



6.) Safety Standards/EMC	
Safety Standards	UL/cUL recognize to UL60950-1 and CSA C22.2 No.60950-1, CB test certificate and report to IEC60950-1, TUV to EN60950-1, CE (EMC and Low Voltage Directive),
EMI	FCC Title 47, Class B / EN55022, CISPR22, CLASS B EN61000-3-2 (Limitation of mains harmonic currents)
EMS	
• EN 61000-4-2 ¹⁾ Electrostatic Discharge Standard (ESD)	Air Discharge: 15 KV Contact discharge: 8 KV
• EN 61000-4-3 ¹⁾ Radiate Field Immunity	LEVEL 3 80MHz - 1GHz / 10V/M with 1kHz tone / 80% modulation.
• EN 61000-4-4 ¹⁾ Fast transients (Burst Immunity)	LEVEL 3 2 KV ⁴⁾
• IEC 61000-4-5 ¹⁾ Surge voltage Immunity	LEVEL 3 Common Mode: 2 KV ³⁾ Differential Mode: 2 KV ⁴⁾
• EN 61000-4-6 ¹⁾ Conducted Immunity	LEVEL 3 150KHz - 80MHz / 10Vrms.
• EN 61000-4-8 ¹⁾ Power frequency magnetic field	LEVEL 3 10A/Meter
• EN 61000-4-11 ²⁾ Voltage dips	Input 100% dip 1 cycle, Main Buffering > 20ms, Self Recoverable
• IEC 61000-4-12 ¹⁾ Low Energy Pulse Test (Ring Wave)	LEVEL 3 Common Mode: 2 KV ³⁾ Differential Mode: 1 KV ⁴⁾
Galvanic Isolation : Input / output Input / PE output / PE	type test/routine test : type test/routine test : type test/routine test : 3KVac 1.5KVac 0.5KVac
1) Criterion A: Normal operating behavior within the defined limits. 2) Criterion B: Temporary impairment to operational behavior that is corrected by the device itself. 3) Symmetrical: Conductor to conductor. 4) Asymmetrical: Conductor to ground. 5) Class B: Area of application industry and residential.	



Engineering Data

- Derating Curve
- PMC-24V150W1AE

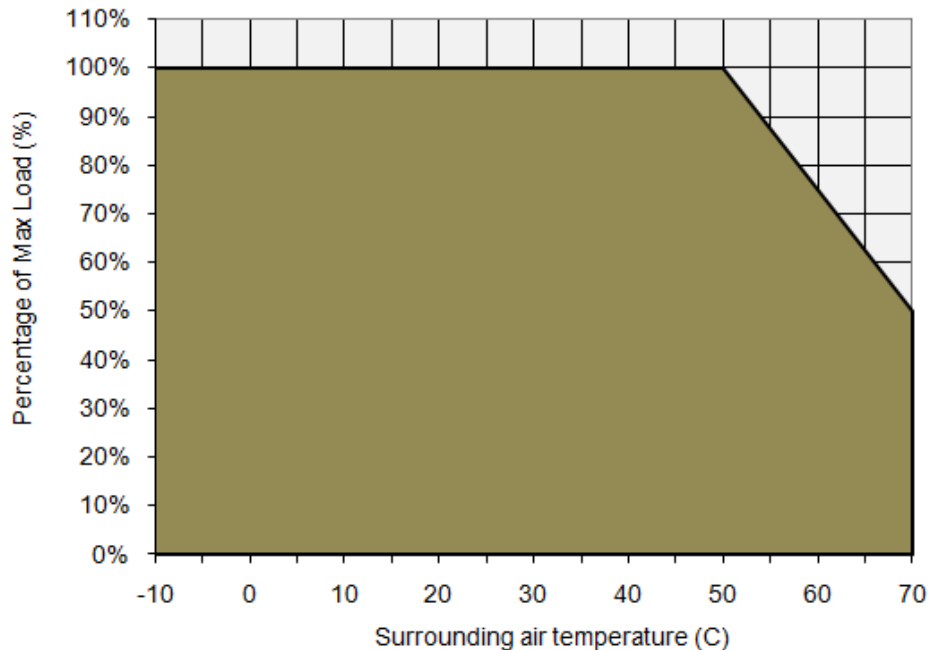

Note:

1. Do not use the Power Supply in areas outside the shaded portion as shown in the above graph, internal parts may occasionally deteriorate or be damaged.
2. For the power derating refer above graph ambient temperature $> 50^{\circ}\text{C}$, the output capacity has to be reduced by 2.5% per Kelvin increase in temperature. If the output capacity is not reduced when $\text{Amb} > 50^{\circ}\text{C}$ device will run into thermal protection by switching off i.e. device will go in bouncing mode and will recover when Amb is lowered or load is reduced as far as necessary to keep device in working condition.
3. If the power supply has to be mounted in any other direction please contact your service provider.
4. In order for the device to function in the manner intended, it is also necessary to observe lateral spacing of 2 cm to other modules.
5. Depending on the ambient temperature and load of the device, the temperature of the housing can become very high!



Mechanical drawing

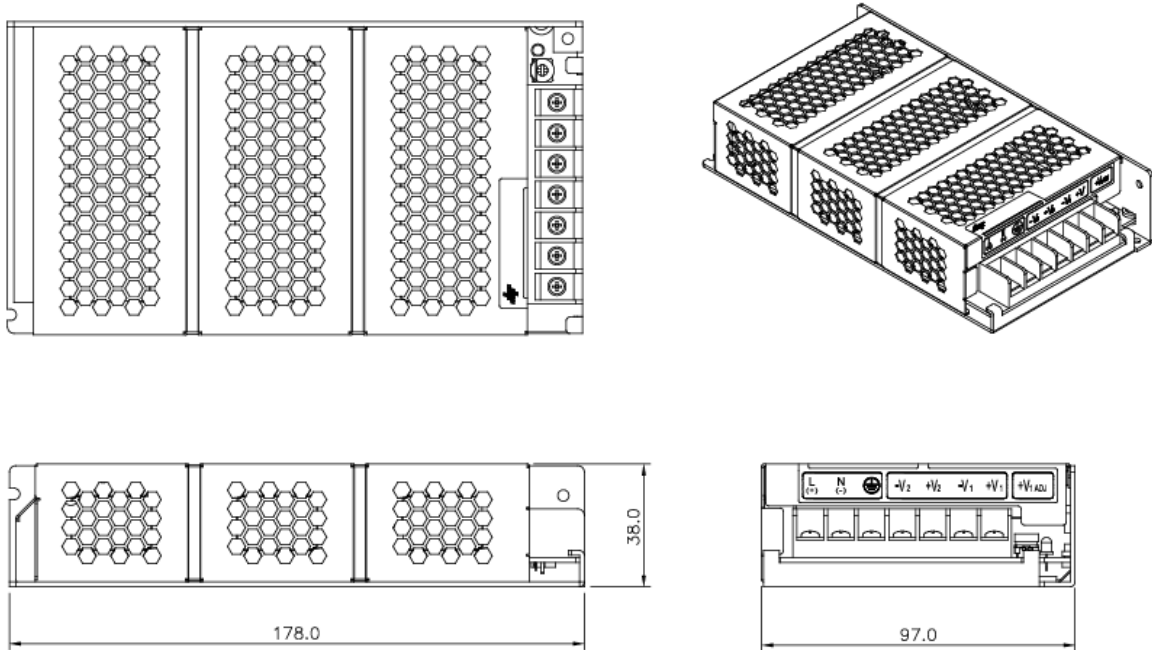

Device description (Fig. 1)

- ① Input & Output terminal block connector
- ② DC voltage adjustment potentiometer
- ③ DC OK control LED (green)

Side Mounting (Vertical) Base Mounting (Vertical) Side Mounting (Horizontal)

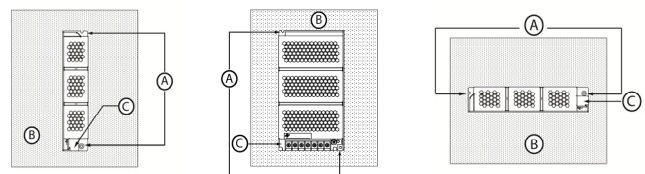

Fig. 1. Mounting Orientation



Fig. 2. Wire Type



- **Over Load Protection**

The Power Supply is provided with an overload protection (OLP/OCP) function which protects the power supply from possible damage by over current. Additionally power supply also has over temperature protection (OTP) in case the over load condition persists for a longer duration and is below the overload trigger point but > 100% load.

Typically the over load current (I_{OL}) is > I_{SURGE} (120%) output voltage will start drooping down when the power supply reaches max power limit and will run into bouncing mode when the output reaches UVLO (under voltage point). The output voltage will recover automatically when the overload condition is removed.

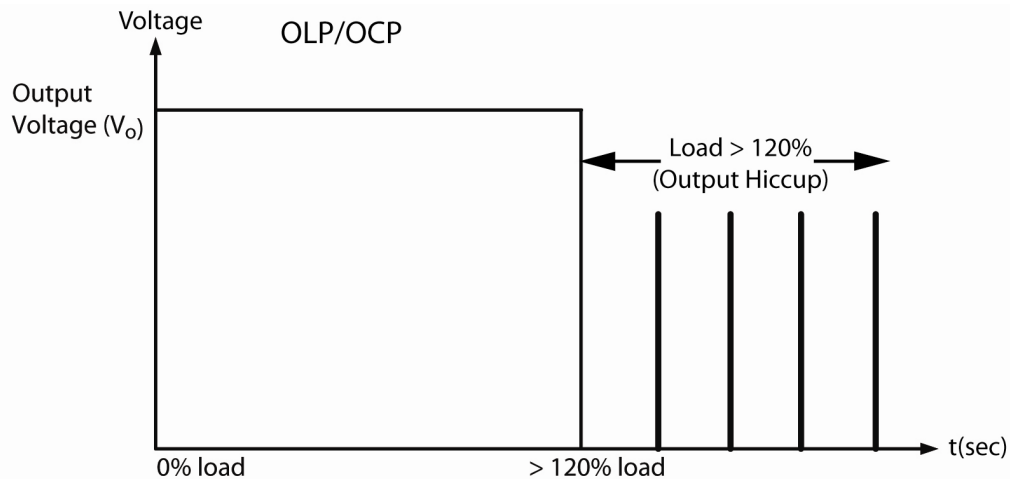

- **Short Circuit Protection**

The Power Supply also has a short circuit protection which is in line with the overload protection and activates whenever there is a short across the output voltage, output goes in bouncing mode and remains until the fault is removed.

- **Over Temperature Protection**

Additionally power supply also has over temperature protection (OTP) as mentioned above this OTP comes into picture when the over load condition persists for a longer duration and the output current level is below the overload trigger point but > 100% load.

Also in the event of a higher ambient operating condition with 100% load the power supply will run into OTP when the Ambient temperature is > 55°C. The protection is self recoverable when activated output voltage bounces until the operating ambient temperature of the power supply is reduced or the power supply is used within its power derating curve.



- **Over Voltage protection**

The Power Supply is protected by Over voltage in the event that power supply feedback circuit fails the output voltage will not be **> 32V, +10%** under any Line/Load and operating ambient conditions.

The unique feature about this over voltage protection (OVP) is that power supply doesn't shut down but goes **Hicc-up mode (Auto recovery) which is 32V, +/-10%**. The power supply output voltage will recover back to 24Vdc once the fault condition is removed.

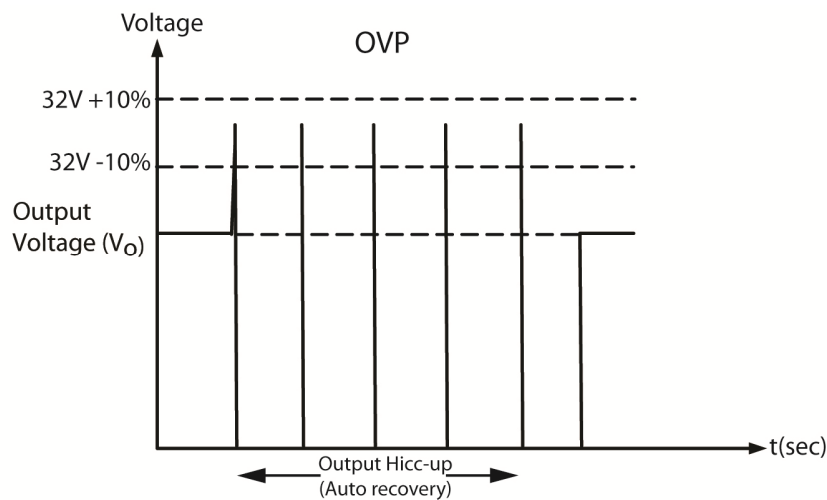

- **Inrush Current, Start Up Time, Output Hold Up Time**

Inrush Current,

Inrush current is the first surge current seen on the input side when AC input is applied to the power supply. It is the first pulse captured; see a typical picture for the Inrush current as seen in the power supply.

Start Up Time,

Start up time is measured from the point AC input is applied and the o/p voltage reaches within 90% of its set value. See picture below for a typical start up time characteristic of a power supply.

Rise Time,

Rise time is the time needed for o/p voltage to rise from 10% of its set value to 90% of its set value. See the picture below for a typical rise time measurement in a power supply.



Hold Up Time,

Hold time is the time when the AC input collapses and o/p voltage retains regulation for a certain period of time is called as hold up time. See in the picture below a typical hold up time characteristic of a power supply. The hold time is measured until the o/p voltage remains in regulation hence it measured until the o/p voltage reaches 95% of its set value.

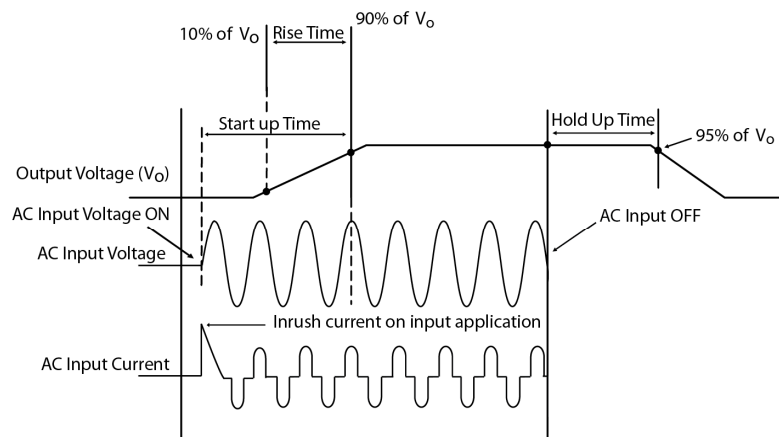

- **Output Voltage Adjust**

The 24VDC connection is made using the "+" and "-" screw connections. At the time of delivery, the output voltage is 24VDC. The output voltage can be set from 22 to 28VDC on the potentiometer seen as Adjust on the front panel of each power supply.



- **Dynamic Load**

Additionally power supply is capable of dynamic change of load from 0% to 100% with o/p voltage within $\pm 5\%$ of regulation limits. See below the dynamic behavior of the PSU.

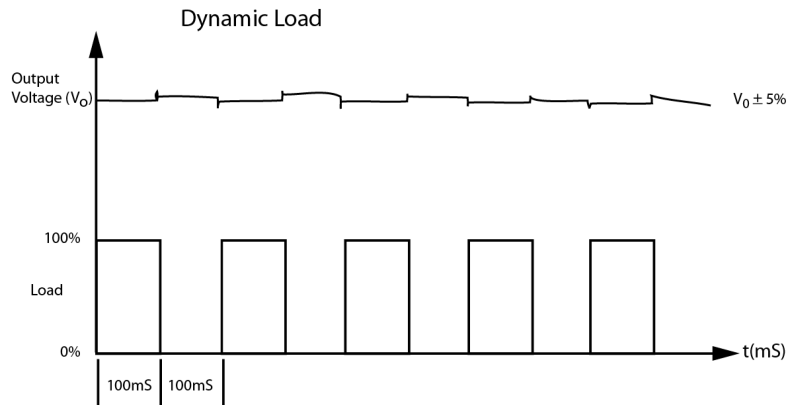

- **Redundancy & Parallel Operation with Oring Diode**

See below figure for a typical Redundant/Parallel operation of PSU using CliQ series power supplies. The 2 power supplies PSU1 & PSU2 are connected thru a twin diode where Anode1 A1 is connected to the +Ve i.e. 24V of PSU1 and Anode2 A2 is connected to the +Ve i.e. 24V of PSU2 and the output ground GND are shorted together.

The output of these 2 power supplies PSU1 & PSU2 is drawn from the Cathode K of the twin diode thus making the power supply work in Redundant/Parallel operation.

Redundant Operation:

When 2 power supplies are connected in below manner the power supply PSU1 or PSU2 whichever has higher output voltage takes the max load and the other PSU is operating in standby (@No Load) in case of failure on PSU1, PSU2 takes over the load from PSU1 and supplies the required power to end system.



- **Redundant / Parallel Operation with External Oring Diode**

Redundance / Parallel Operation with External Oring Diode

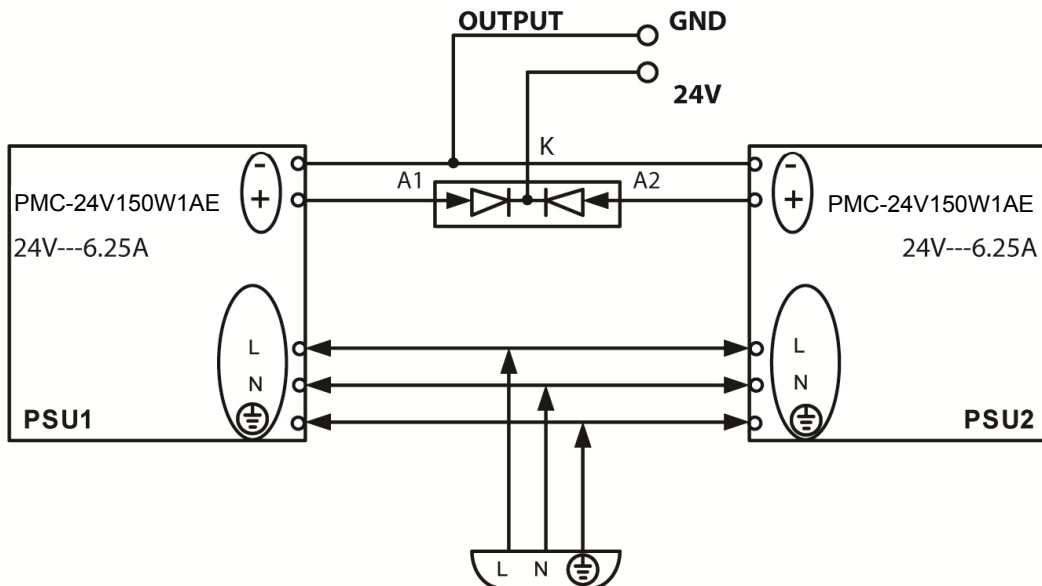
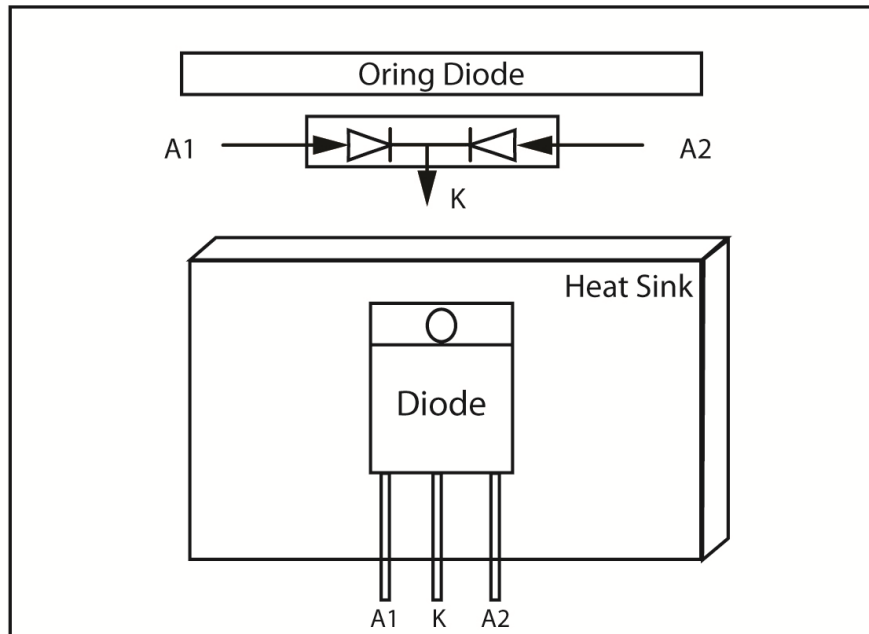

**Parallel Operation:**

When 2 power supplies are also connected in the above manner they can share the Load provided following steps are taken.

Step 1:

Measure the o/p voltages @ NL measured from A1 to Gnd i.e. VA1 to Gnd of PSU1 and VA2 to Gnd of PSU2. If the voltages are not same follow step 2, if the o/p voltages are same skip step 2 and move to step 3.

Step 2:

Adjust the o/p voltages with the help of VR available on the front panel of the PSU marked as ADJUST for both PSU1 and PSU2 at the same level for e.g. if PSU1 o/p is measuring 24.15Vdc and PSU2 is measuring 24.25Vdc adjust the o/p voltage of either PSU1 close to 24.25Vdc or adjust the o/p voltage of PSU2 close to 24.15Vdc.

Step 3:

Connect the PSU to the end system load and measure the o/p voltages from A1 to Gnd i.e. VA1 to Gnd of PSU1 and VA2 to Gnd of PSU2. Ensure that o/p voltages are same even after the 2 power supplies are connected to load. If not then adjust them with the VR available on Front panel. A tolerance of $\pm 25\text{mV}$ would be acceptable.

Note:

1. If the o/p voltage of any 1 power supply i.e. PSU1 or PSU2 is higher that power supply will take the initial load and also share the maximum load.
2. If the o/p voltages adjusted are same then an equal load current sharing between the 2 power supplies can be achieved.
3. The Oring diode must be of an appropriate rating, recommended rating of Oring Diode is minimum 4 times of the output load current and minimum reverse voltage rating of 45Vrr.
4. A suitable HS is also advised to ensure that oring Diode is not over heated and damaged.